

NORBIT - iWBMSH STX HIGH-END TURNKEY MULTIBEAM SONAR SYSTEM

For High Resolution 3D&4D Bathymetric Survey

Go-anywhere, go-anytime ultra-high 3D resolution curved-array bathymetric mapping solution featuring industry leading GNSS/INS positioning system from NORBIT.

This most compact, highest resolution, tightly integrated, broadband multibeam sonar solution offering a curved array and GNSS/INS that is suited for the most demanding environments (Applanix OceanMaster). The iWBMSH STX is ready for rapid mobilisation and delivers highest XYZ performance for the price.

The iWBMSH STX is fully integrated with the highest performing sensors to work in the most challenging environments (under bridges or in rough sea conditions). Small form factor, low power draw and tight integration allow installation on any survey platform (permanent hull mount or pole mount). NORBIT STX uses rapid electronic transmit beam scanning to combine proven 2D bathymetry into 3D georeferenced bathymetry. For dredge application, a 4D experience is achieved by visualising the change in 3D bathymetry as a function of time. Hands-free system tuning ensures quality data on the first survey. Supported by DCT (Data collection Tool) for data acquisition.



Features

- ✓ Multibeam Sonar with Integrated Inertial Navigation System & Integrated NTRIP Client
- ✓ 80kHz Bandwidth
- ✓ Roll-stabilisation
- ✓ Backscatter outputs (Intensity, Sidescan, Sidescan Snippets, Snippets, Water Column)
- ✓ Multidetect
- ✓ Simple Ethernet Interface
- ✓ Integrated Sound Velocity Probe
- ✓ GPS Antennas included
- ✓ FM & CW Processing
- ✓ Flexible Power Option
- ✓ Exceeds IHO *Special Order*, CHS *Exclusive Order* & USACE *New Work*

Applications

- ✓ 3D&4D Bathymetry
- ✓ Coastal Zone and Offshore Bathymetry
- ✓ Pipeline Surveys
- ✓ Pond, River and Estuary Surveys
- ✓ Harbor and Lake Surveys
- ✓ USV Ready

Options

- ✓ Senior Hydrographer for Support and Training
- ✓ Sound Velocity Profiler
- ✓ Data Collection Tool (DCT)
- ✓ Turnkey Survey Solutions
- ✓ Permanent Hull Mount Option
- ✓ Pole Mount and Travel Option
- ✓ Acquisition, Navigation and Post Processing Software
- ✓ Backscattering Strength Output
- ✓ 1024 HDS
- ✓ Can be Delivered with all Major Software Packages e.g. DCT, HYPACK, Qinsy, EIVA, CARIS and Others

EXPERTS in sensor equipment providing telemetry and communication solutions for harsh environments.
NORBIT develops and delivers innovative products - allowing you to explore more.

NORBIT - iWBMSH STX

For High Resolution 3D Bathymetric Survey

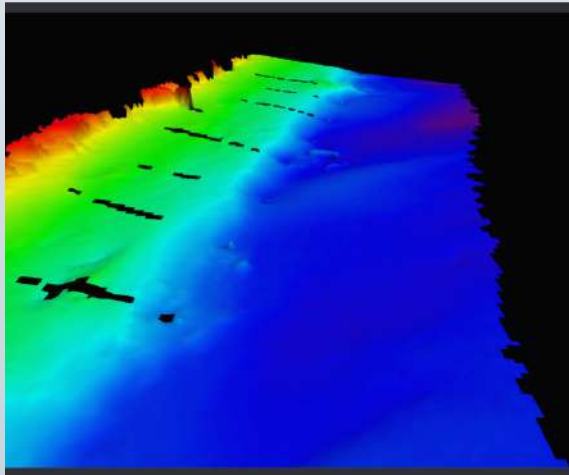

One line of data without multidetect and STX scanning, shadows behind the piling and pilings aren't visible.

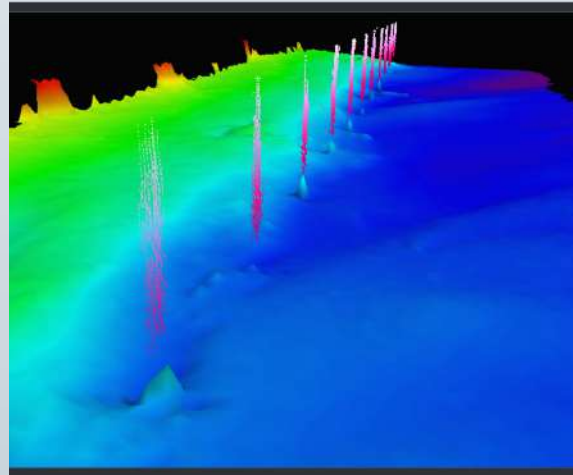

One line of data with multidetect and STX scanning enabled, no shadows behind the piling and pilings are visible.

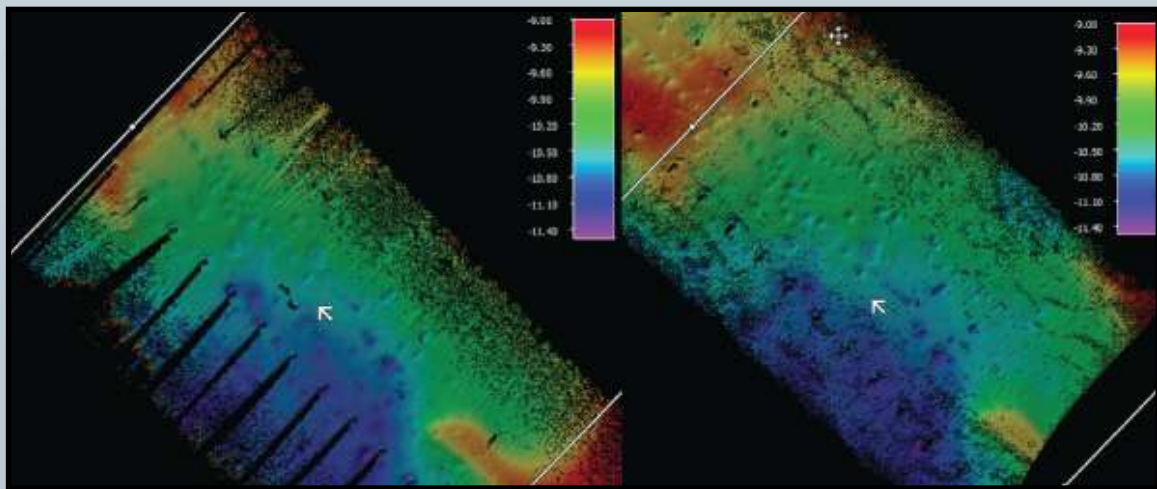

TECHNICAL SPECIFICATION

SWATH COVERAGE	5-210° FLEXIBLE SECTOR (SHALLOW WATER IHO SPECIAL ORDER >155°)
DEPTH RESOLUTION	<6mm w. 80kHz ACOUSTIC BANDWIDTH
NUMBER OF BEAMS	256, 512 (HDS 1024) EA & ED
OPERATING FREQUENCY	NOMINAL FREQUENCY 400kHz (FREQUENCY AGILITY 200-700kHz)
DEPTH RANGE	0.1m-275m (160m TYPICAL)
PING RATE	UP TO 60Hz, ADAPTIVE
RESOLUTION (ACROSS X ALONG)	STANDARD: 0.9° X 0.9° @400kHz AND 0.5° X 0.5° @700kHz
POSITION	HOR: ±(8mm +1ppm X DISTANCE FROM RTK STATION) VER: ±(15mm +1ppm X DISTANCE FROM RTK STATION) (ASSUMES 1m GNSS SEPARATION)
HEADING ACCURACY	0.02° (RTK) WITH 2m ANTENNA SEPARATION
PITCH/ROLL ACCURACY	0.01° INDEPENDENT OF ANTENNA SEPARATION
HEAVE ACCURACY	2 cm OR 2% (TRUEHEAVE™), 5 cm OR 5% (REAL TIME)
WEIGHT	10.1kg (AIR) LESS THAN 5.1kg (WATER)
INTERFACE	ETHERNET
CABLE LENGTH	STD CABLE LENGTH 8m, OPT: 2m, 25m AND 50m
POWER CONSUMPTION	70W (10-28VDC, 110-240VAC)
OPERATING TEMP.	-4°C to +40°C (TOPSIDE -20°C to +55°C)
STORAGE TEMP.	-20°C TO +60°C
ENVIRONMENTAL	TOPSIDE: IP67: DUST TIGHT, PROTECTED AGAINST THE EFFECT OF IMMERSION UP TO 1m/WET-END (SONAR): 100m

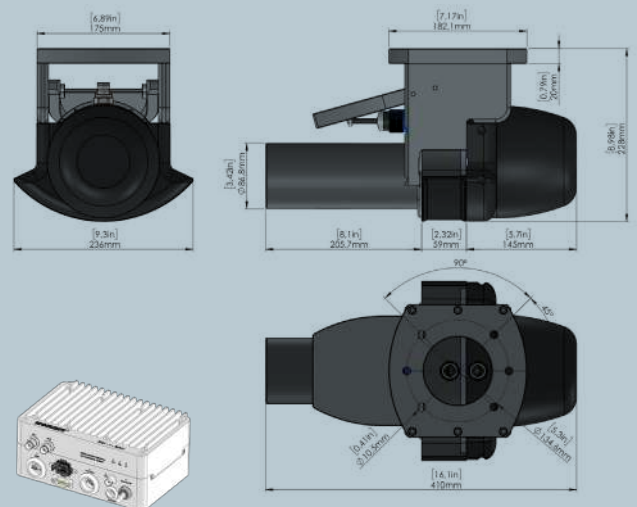

Part no: 12007-APBDD4